



*Shown:
Optional Wheel Cart

VIPER 
GAS

 AIR COMPRESSOR

Now Smaller, Quieter, and Double the Fuel Capacity!

The redesigned Viper™ Gas Rotary Screw Air Compressor allows you to get in and out of the job site fast. Featuring a larger fuel tank to provide six and a half hours of runtime at 70% duty cycle gets you through multiple projects, without having to halt production to refuel. A smaller footprint saves valuable trailer or truck bed space for more tools. Low idle RPMs reduce noise, providing a quieter experience for you to work in. As if that wasn't enough, sensors automatically unload the compressor during startup, and the auto start-stop turns on with air demand. The heavy-duty 80 CFM and 100 PSI air pressure make this unit the ideal choice to operate: 90 Lb. jackhammers, 4" piercing tools, pavement breaking, monument engraving, irrigation services, post-pounding, directional boring, and more.

SPECIFICATIONS			
Model	G60	G70	G80
Capacity (CFM)	60	70	80
Air (PSI)	150	125	100
Engine (RPM)	3600	3600	3600
Engine (HP)	Honda® 25	Honda® 25	Honda® 25
Fuel Capacity	10 Gallon	10 Gallon	10 Gallon

Viper™ Gas Unit Dimensions (In.): 39L x 21W x 30H | 40L x 25W x 32H With Fittings | Dry Weight (Lbs.): 440



AIR COMPRESSOR

- Lifetime Warranty
- Rotary Screw
- Vanair® Encapsulated Air End
- Belt-Driven

ENGINE

- Honda® iGX800 EFI, 25 HP
- Gasoline
- 4-Cycle, V-Twin, Overhead Valve
- 10 Gal. Fuel Tank

INSTRUMENTATION

- Temperature Indicator
- Engine Diagnostic Lamp
- Hour Meter
- Digital Pressure Display

CANOPY

- Powder-Coated Galvanneal Sheet Metal
- Lifting Bail

MAINTENANCE

- Easy Service Access
- Removable Panels and Hinged Top for Serviceability

SAFETY EQUIPMENT

- Air Pressure-Relief Safety Valve
- Minimum Pressure Valve
- Automatic Blowdown on Shutdown
- Low Engine Oil Pressure Shutdown
- High Compressor Temperature and Pressure Shutdown

OPTIONS/ACCESSORIES

- Remote Start/Stop
- Remote Dual Pressure
- Cold Weather Package
- Service/Control Line Moisture Separators
- Filter/Lubricator/Regulator (FLR)
- Tool Oiler/Lubricator
- Air Hoses, Hose Reels, and Fittings
- OSHA Safety Valve (Velocity Fuse)
- CARB Canister
- Maintenance Kits
- Wheel Cart
- Load Space Air Baffle

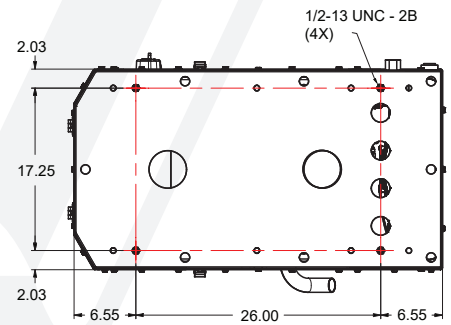
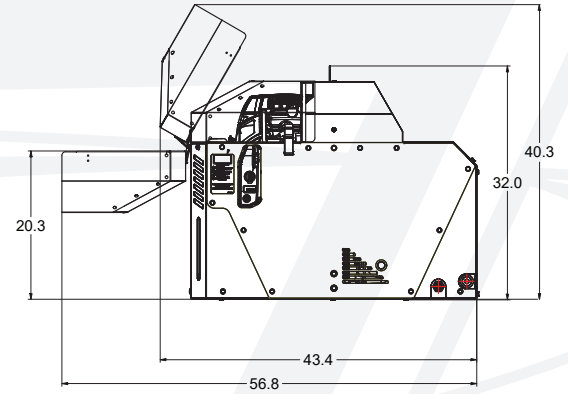
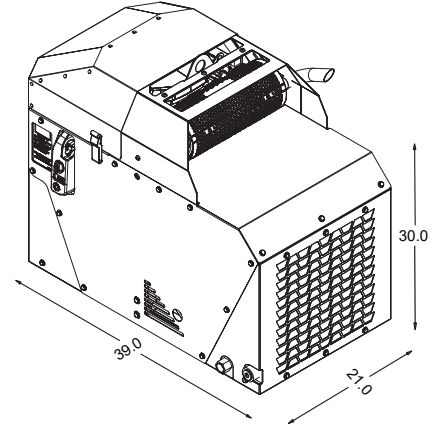

MOUNTING HOLES

Vanair® reserves the right to make changes in engineering, design, and specifications; add improvements; or discontinue manufacturing at any time without notice or obligation. Vanair®, the Vanair® logo and MOBILE POWER SOLUTIONS® are registered trademarks or trademarks of Vanair® Manufacturing, Inc., Michigan City, IN, USA. © 2023 All Rights Reserved.



VANAIR
MOBILE POWER SOLUTIONS®

800.526.8817 | vanair.com